



Strip Coil의 불량을 방지하기 위한 고객사는 불량품의 後 공정 유입방지 및 불량품 출하방지를 위한 전장길이 품질 Data 인프라의 표준화 및 제어정도 향상으로 제품 품질 확보한다

**품 명 : Strip Coil Data Transfer Gathering Software Program**

**품목 Code : PMPLC-APP-SWDTG-100**

# 1. 제어시스템의 구성

## ➔ System Configuration

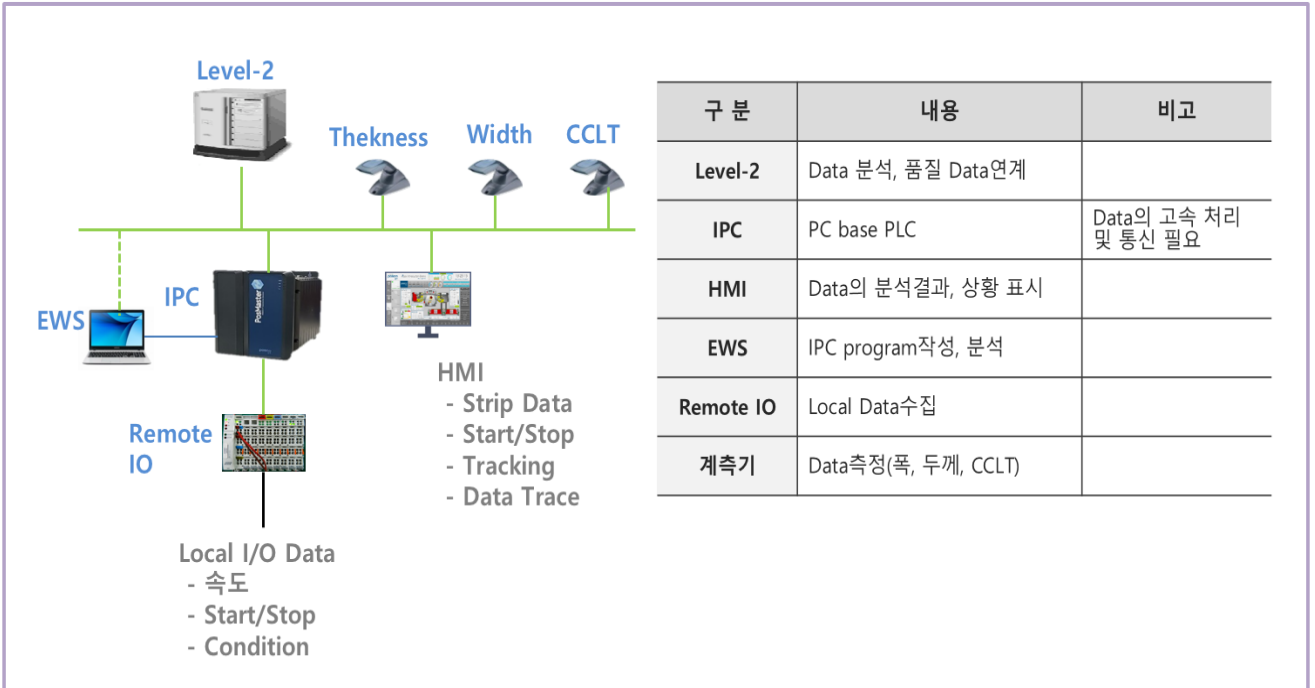

## ➔ 시스템 Block도

예 1). EGL

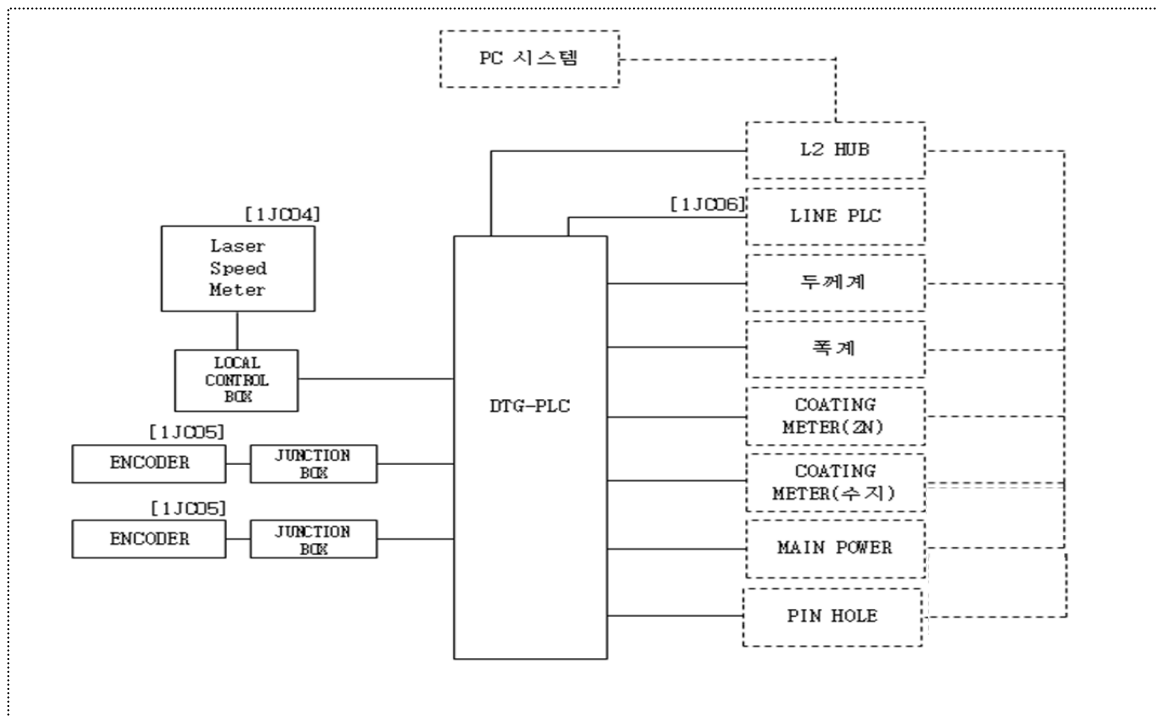

예 2) CSL

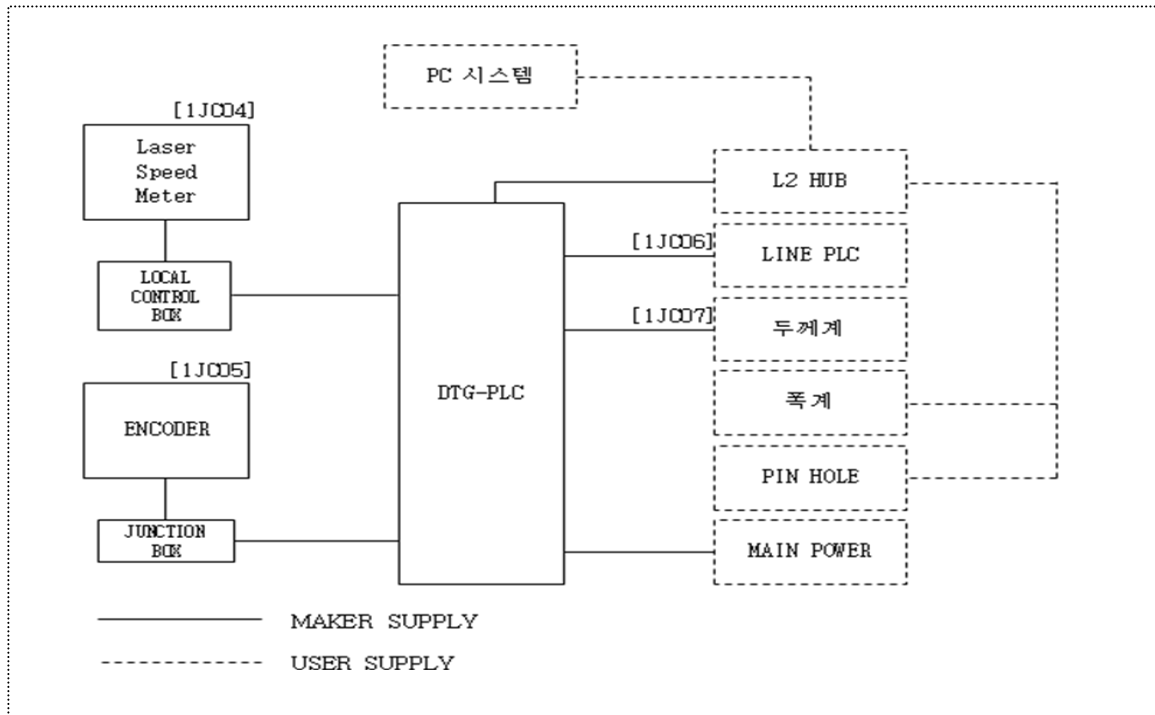

예 3) CAL

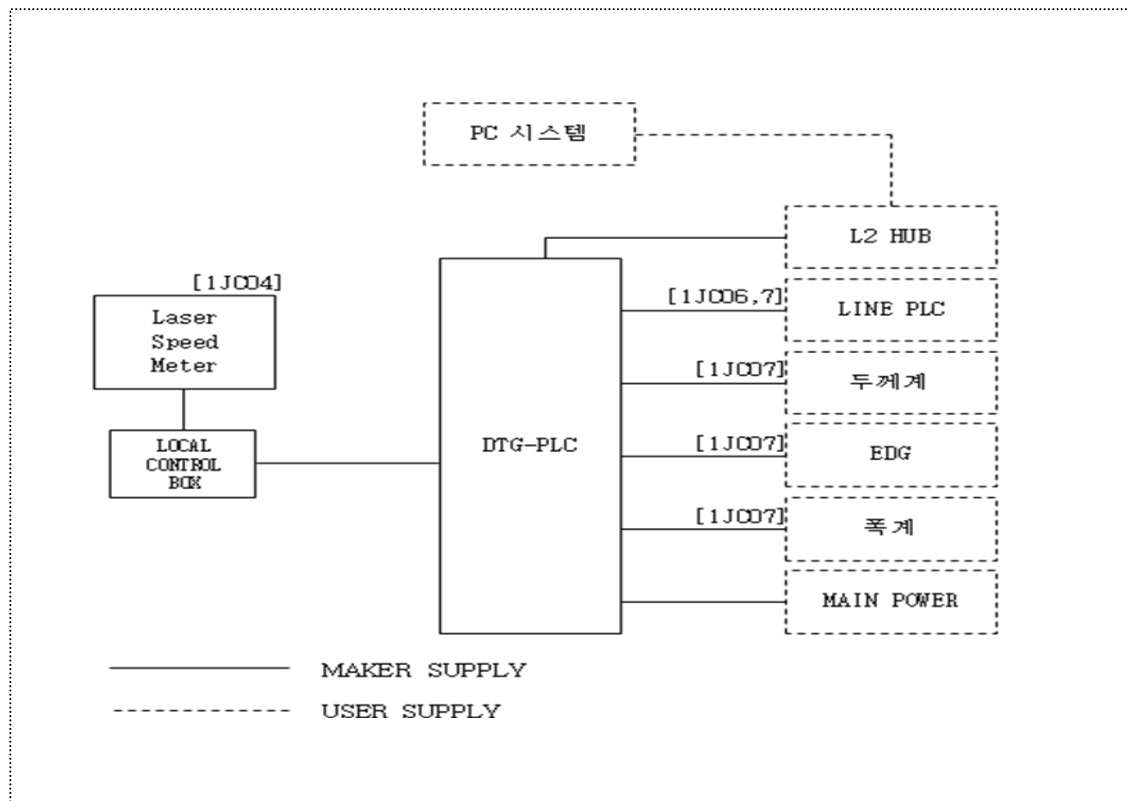

## 예 4) PCM

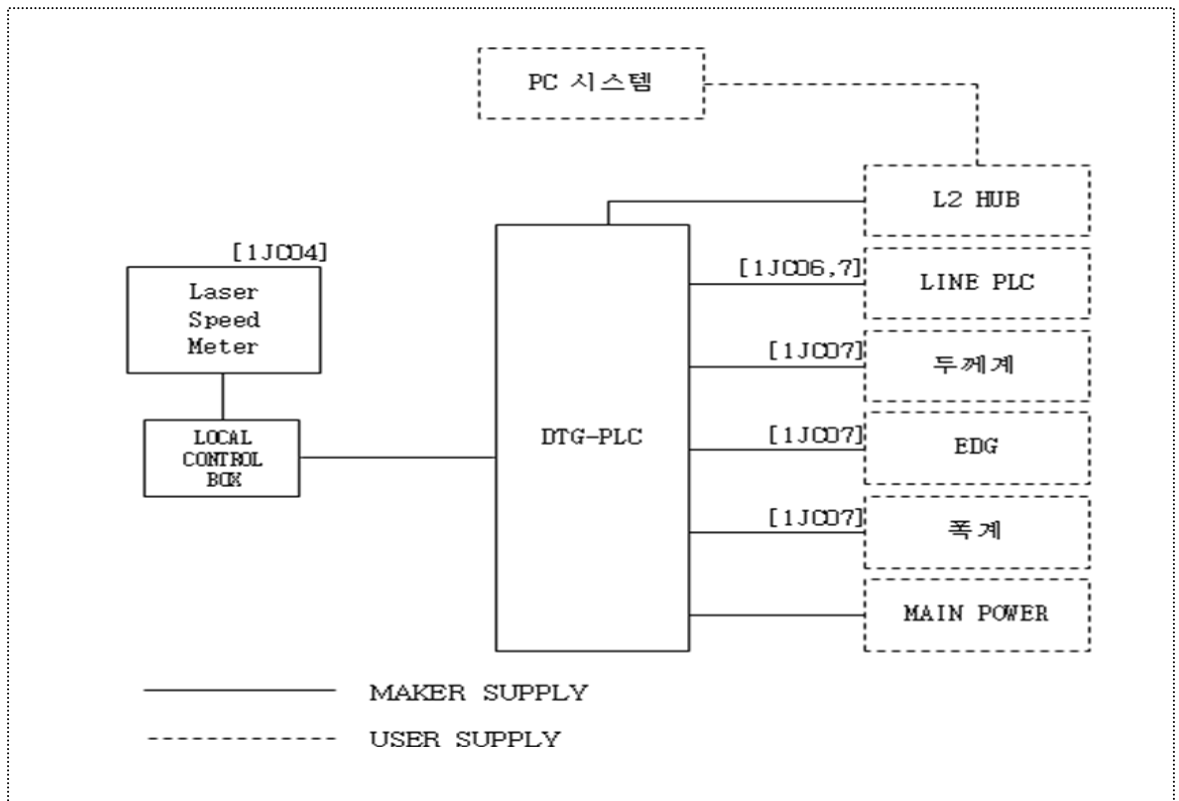

## System개념

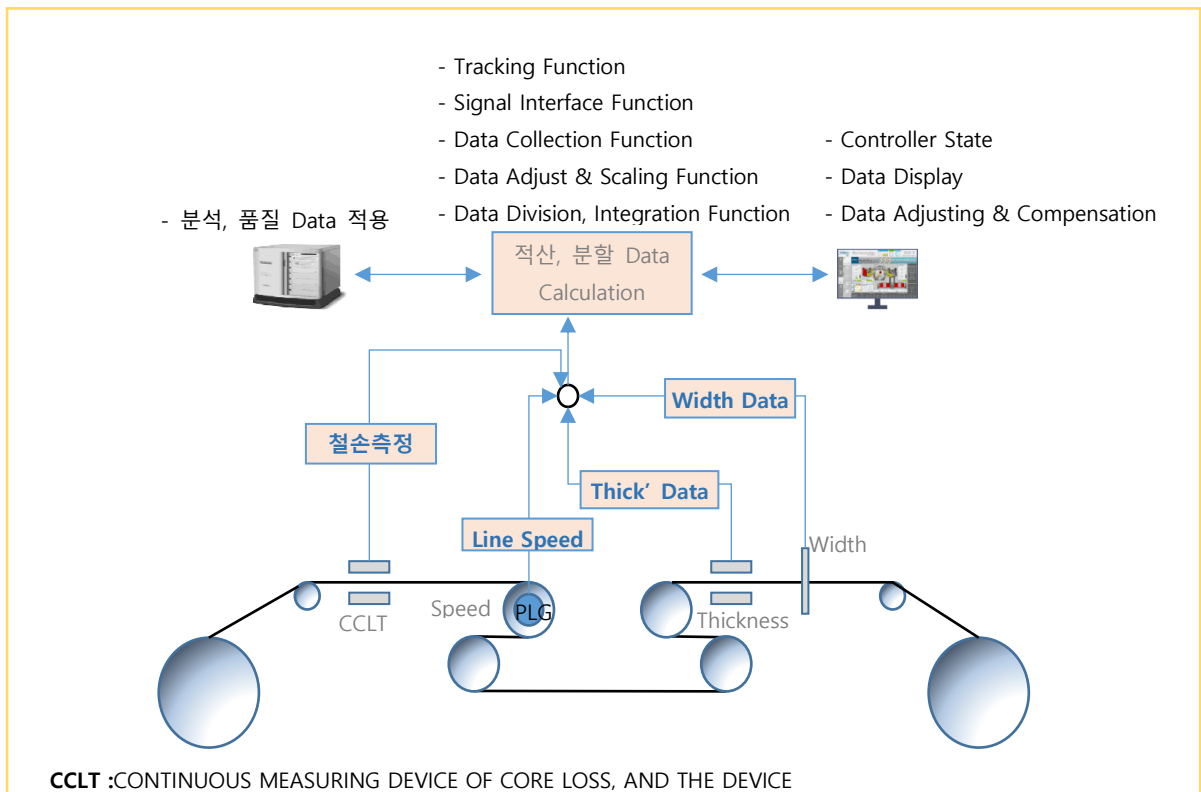

## 2. 제어 Software 기능

### Tracking Function

